

OIL AND GAS SECTOR MACHINING SOLUTIONS – Internal Slot and keyway milling

The Oil, Gas and energy industry component requirements have provided a number of unique machining problems. The need for more innovative extraction methods have meant more complex components and more advanced machining solutions. With many requirements for the machining of long internal keyways, slots and spline forms .

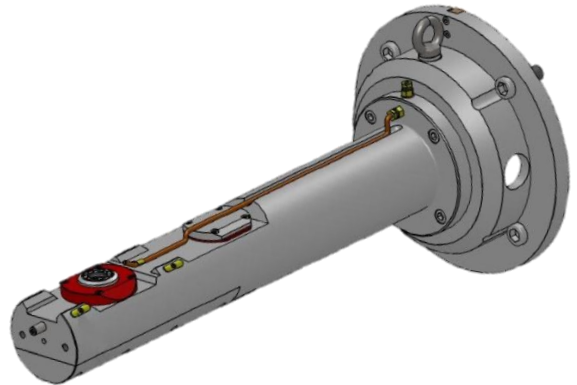

CTL CENTRELINE has many milling and drilling head solutions in the field with the ability to access bore sizes as small as 40mm and reaches of over 1 metre can be accommodated with fully supported cuts. Tools are normally mounted on Horizontal Borers, but both Vertical and Horizontal drive solutions are available.

Internal Locknut Collet Chucks allow for better spindle bearing support allowing higher capacities to be mounted into a smaller body size. Helical and Spiral bevel gear drives are used and all heads are grease lubricated and fully sealed against ingress of coolant and chips etc.

